

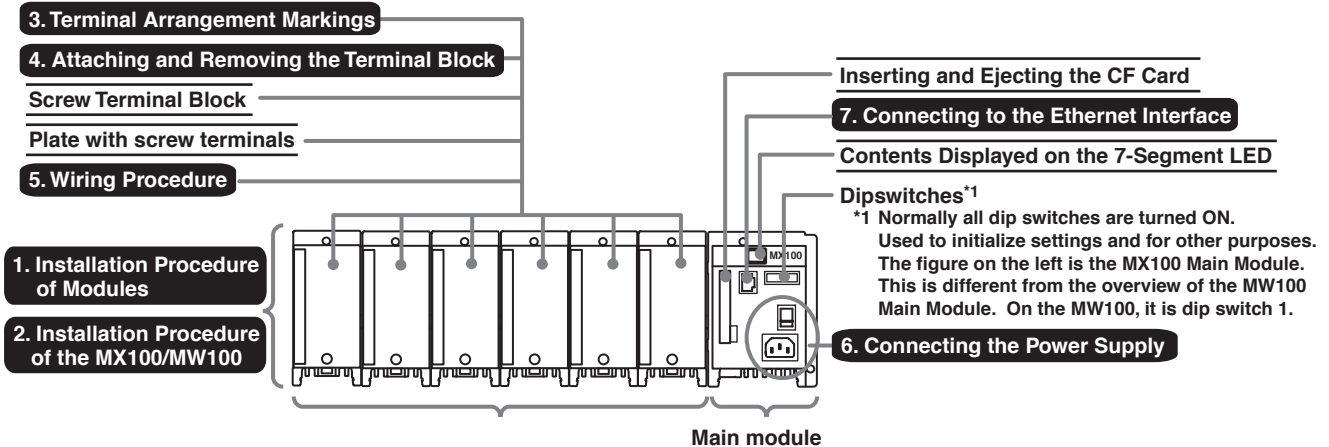

Foreword

Thank you for purchasing the MX100/MW100 Data Acquisition Unit. This guide describes concisely the installation and wiring procedures of the MX100/MW100 Data Acquisition Unit. For more details on this topic as well as safety precautions (be sure to read), and the descriptions of the functions and operations of the MX100/MW100 Data Acquisition Unit, see the MX100/MW100 Data Acquisition Unit User's Manual (electronic manual in PDF format) which is contained in the CD-ROM provided.

Overview of the Operation



Types of Input/Output Modules

- 4-CH, High-Speed Universal Input Module (MX110-UNV-H04)
- 30-CH, Medium-Speed DCV/TC/DI Input Module (MX110-VTD-L30)
- 4-CH, Medium-Speed Strain Input Module (MX112-B12-M04)
- 4-CH, Medium-Speed Strain NDIS Input Module (MX112-NDI-M04)
- 10-CH, High-Speed Digital Input Module (MX115-D05-H10)
- 8-CH, Medium-Speed Analog Output Module (MX120-VAO-M08)
- 10-CH, Medium-Speed Digital Output Module (MX125-MKC-M10)
- 10-CH, Medium-Speed Universal Input Module (MX110-UNV-M10)
- 6-CH, Medium-Speed Four-Wire RTD Resistance Input Module (MX110-V4R-M06)
- 4-CH, Medium-Speed Strain Input Module (MX112-B35-M04)
- 10-CH, Pulse Input Module^{*2} (MX114-PLS-M10)
- 10-CH, High-Speed Digital Input Module (MX114-D24-H10)
- 8-CH, Medium-Speed PWM Output Module (MX120-PWM-M08)

*2 Modules compatible with the MW100.

1. Installation Procedure of Modules

• Attaching the Module

1. Prepare the base block.

When attaching the **MW100**, replace the current base block BRACKET with the BRACKET that came with the MW100.

Remove the base block bracket

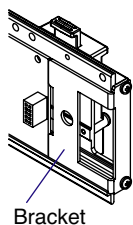

Attach the bracket that came with the MW100

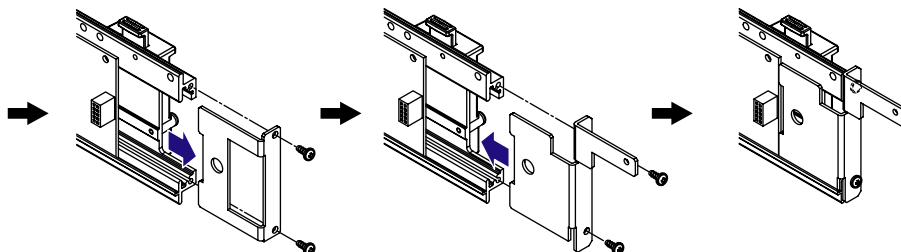

When attaching the **MX100**, if using a conventional version of the main module, remove the base block BRACKET. If the main module has been reworked, use the existing base block as-is. See "MX100/MW100: Handling of the Base Block (Model MX150-□)" in IM MX100-75.

2. Check that the power supply is not connected to the main module.

1. Installation Procedure of Modules

- Align the connector on the rear panel of the module to the connector at the desired position of the base plate and insert the connector. When the connectors are correctly connected, the guide pin on the rear panel of the module is inserted into the guide hole on the base plate. Then, the module is secured to the base plate with the latch lever locking in place at the bottom section of the base plate. Note that the main module can only be attached to the right end of the base plate.
- For the **MX100** main module, attach using a screw (M3) at the top of the module.
For the **MW100** main module, attach using screws (M3) in two locations at the top of the module.

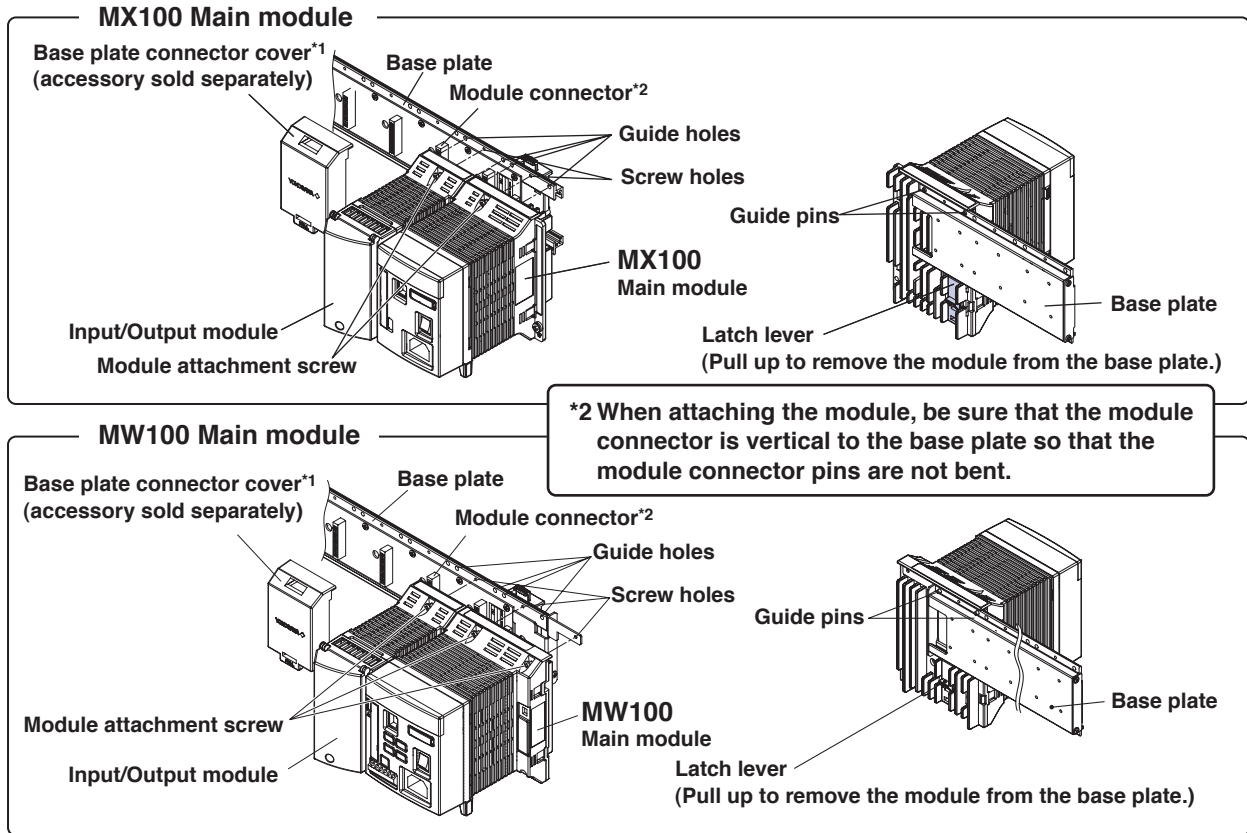

*1 Can be attached by hooking the top section of the cover to the top edge of the base plate and pressing down on the lower section of the cover

• Detaching the Module

Loosen the attachment screw, pull down on the latch lever on the rear panel of the module, and pull the module straight from the base plate.

• Attachment Positions and Channel Numbers

The figure below shows how the channel numbers are identified on the PC. The **MW100** channel numbers are only displayed when viewing measured data on the MW100 Viewer software.

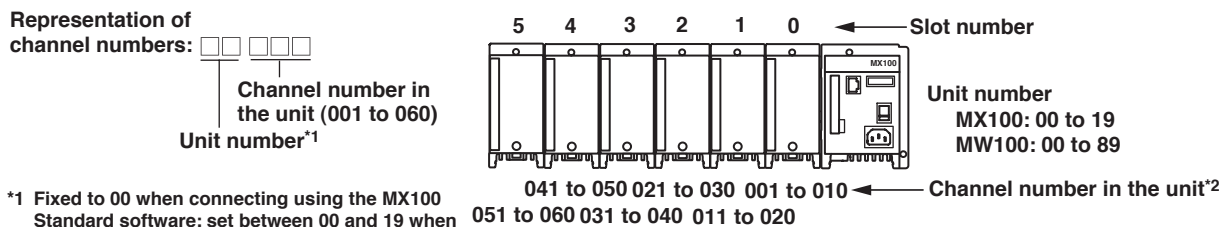

*1 Fixed to 00 when connecting using the MX100 Standard software; set between 00 and 19 when using MXLOGGER software; and set between 00 and 89 when using the MW100 Viewer software.

*2 The last one digit on a 4-channel module is 1 to 4, the last one digit on a 6-channel module is 1 to 6, the last one digit on a 8-channel module is 1 to 8.

Note

The 30-CH Medium Speed DCV/TC/DI Input Module takes up three modules worth of space when attaching to the base plate.

2. Installation Procedure of the MX100/MW100

The MX100/MW100 Data Acquisition Unit can be used on a desktop, on a floor, in a rack mount, or in a panel mount. In all cases, be sure to install the instrument in a vertical position.

- **Use on a Desktop or a Floor**

Each module has feet that can be attached to the base plate allowing them to be placed vertically.

- **Attachment to a DIN Rail**

As shown in the figure below, you can rack-mount or panel-mount the MX100/MW100 Data Acquisition Unit by attaching a DIN rail mount bracket to the base plate.

- Attachment of the DIN rail mount bracket to the base plate
- Attachment of the base plate to the DIN rail

Bracket (brackets for the MX100 and MW100 have different shapes)

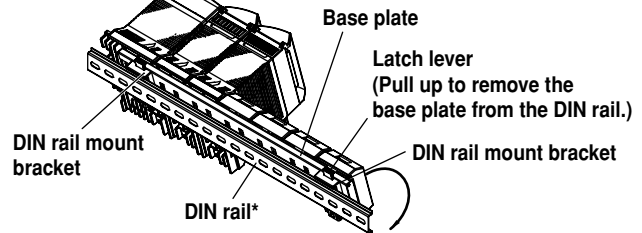
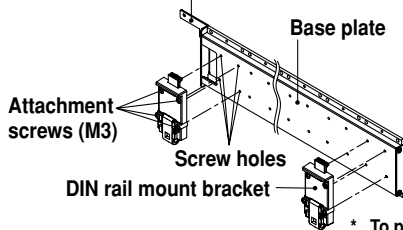

* To prevent slacks in the DIN rail, fix at least three locations of the DIN rail.

3. Terminal Arrangement Markings

A character indicating the terminal function and a terminal symbol indicating the type of signal to be input/output to each terminal are written on the back of the terminal cover of each I/O module.

4-CH, High-Speed Universal Input Module

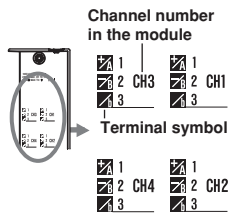

10-CH, Medium-Speed Universal Input Module

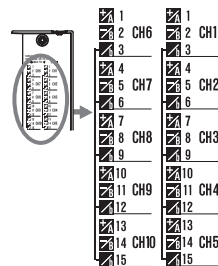

30-CH, Medium-Speed DCV/TC/DI Input Module (clamped terminal)

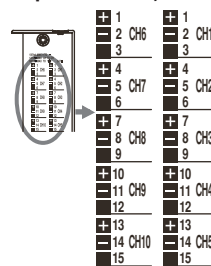

30-CH, Medium-Speed DCV/TC/DI Input Module (screw terminals)

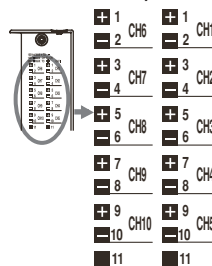

6-CH, Medium-Speed 4-wire RTD Resistance Input Module

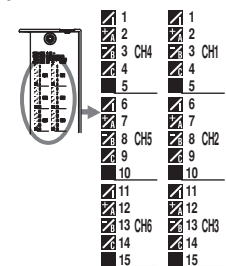

4-CH, Medium Speed Strain Input Module

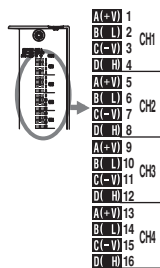

10-CH, Pulse Input Module 10-CH, High-Speed Digital Input Module

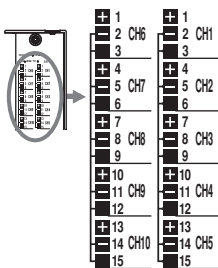

8-CH, Medium-Speed Analog Output Module

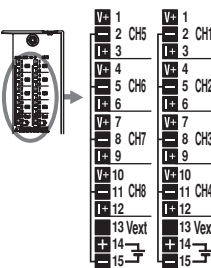

8-CH, Medium-Speed PWM Output Module

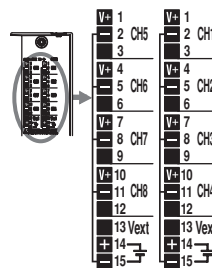

10-CH, Medium-Speed Digital Output Module

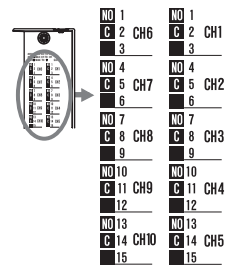

4. Attaching and Removing the Terminal Block

The terminals of the input/output modules in the figure below can be removed.

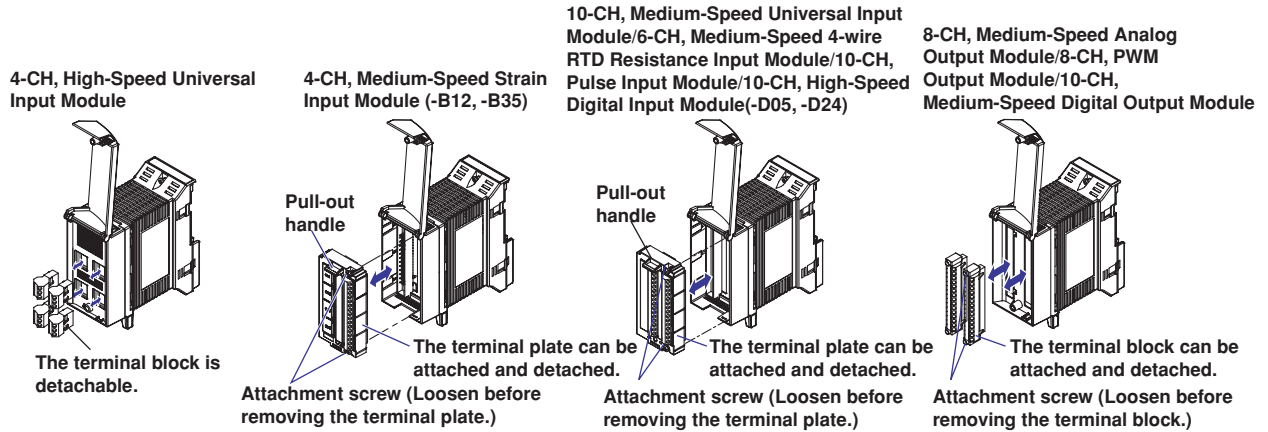

Screw Terminal Block

You can connect a 10-channel screw terminal block (accessory sold separately, M4 screws) that can be attached to a DIN rail (see the figure below) to the 10-CH, Medium-Speed Universal Input Module, 10-CH, Pulse Input Module, and 10-CH, High-Speed Digital Input Module (-D05, D24).

To do so, remove the terminal plate from the module (not necessary with the /NS option since it has no terminal plate).

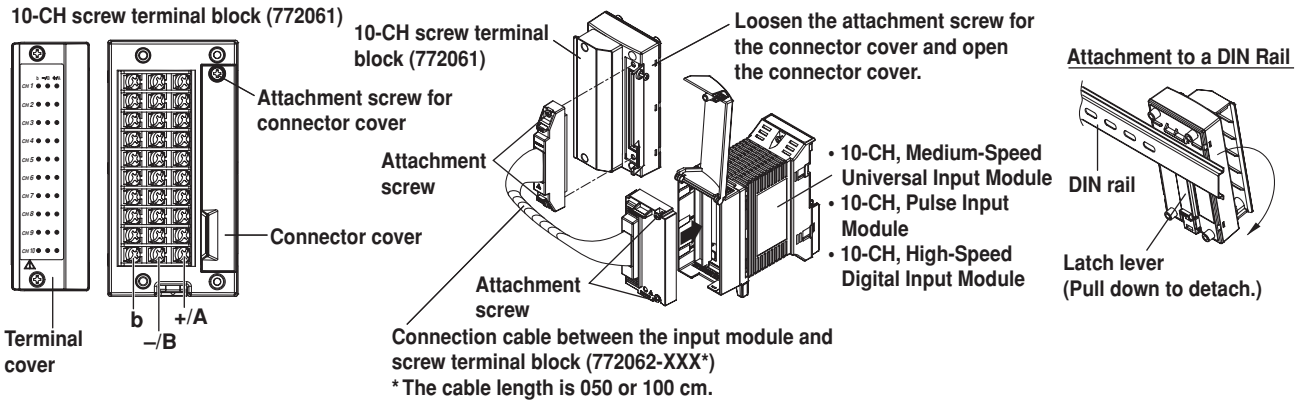

Plate with Screw Terminals / Plate with Clamp Terminals for Current

You can attach the plate with screw terminals (sold separately) to the 10-CH, Medium-Speed Universal Input Module, 10-CH, Pulse Input Module, and the 10-CH, High-Speed Digital Input Module (-D05 and -D24).

Also, you can attach the plate with clamp terminals for current (sold separately) to the 10-CH, Medium-Speed Universal Input Module. To do so, remove the terminal plate from the module (not necessary for the /NS option since it has no terminal plate).

Plate with Screw Terminals (model: 772080)

• Appearance

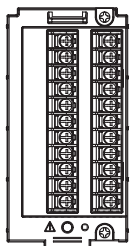

• Terminal arrangement marking on the terminal cover

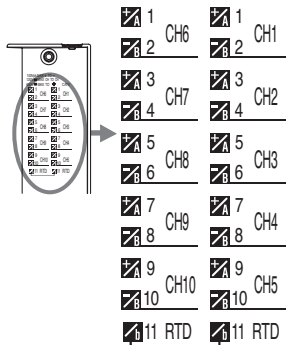
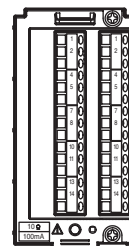
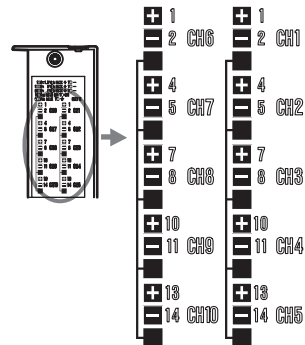

Plate with Clamp Terminals for Current (model 772081 (10 Ω)/772082 (100 Ω)/772083 (250 Ω))

• Appearance



• Terminal arrangement marking on the terminal cover



Attaching the Terminal Cover

1. Loosen the terminal cover attachment screw, then flip up the terminal cover in the direction of the arrow as shown in the figure.
2. Loosen the terminal block screw, then remove the terminal block.
3. Attach the screw terminal plate or the plate with clamp terminals for current, and fasten with screws.
4. Attach the terminal cover that came with the plate with screw terminals or plate with clamp terminals for current.

• **Example of attaching the plate with screw terminals.**

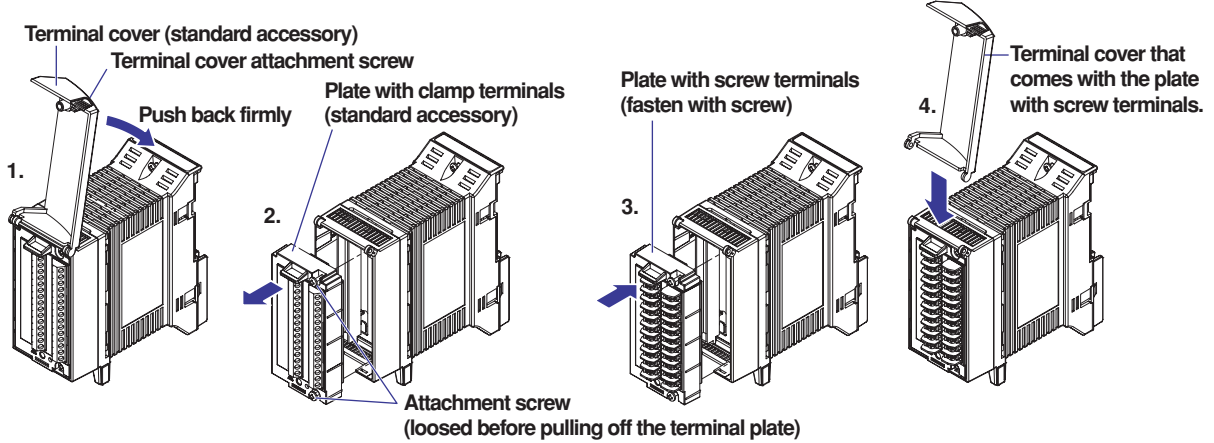

Note

The plate with screw terminals is recognized by the PC software as a clamp terminal. The terminal arrangement of the plate with screw terminals differs from that of the clamp terminal. Follow the terminal arrangement markings on the terminal cover when wiring.

5. Wiring Procedure

1. Turn OFF the power to the MX100/MW100.
2. Loosen the terminal cover attachment screw and lift up the terminal cover.
3. Connect the signal wires to the terminals.
4. Return the terminal cover to the original position and secure it with the screw.

The appropriate screw tightening torque is 0.6 N·m.

4-CH, High-Speed Universal Input Module

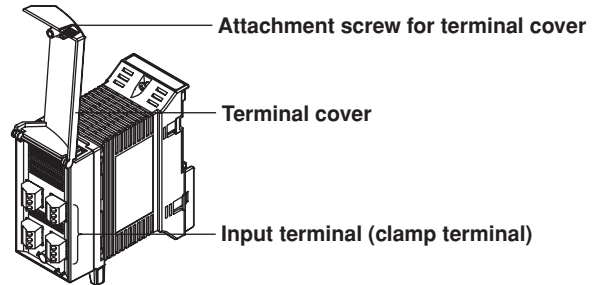

• **Wiring the Universal Input Module and DCV/TC/DI Input Module**

• **Thermocouple input**

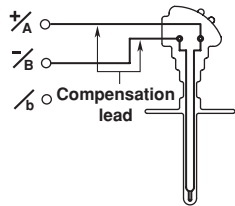

• **RTD input**

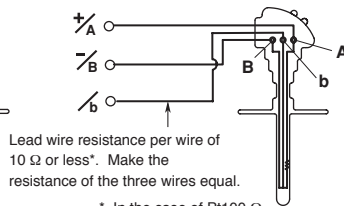

• **DC voltage input/DI input (contact)**

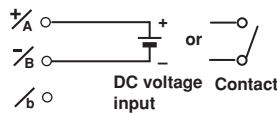

• **DC current input**

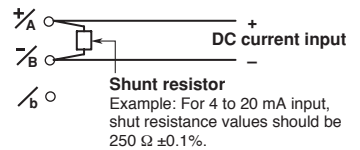

A plate with clamp terminals for current with built-in shunt resistance can be attached to the 10-CH, Medium-speed Universal Input Module.

Terminal type: Clamp, or screw (in the case of M3: -L30/H3)
Applicable wire size: -H04: 0.2 to 2.5 mm² (AWG24 to 12)
-M10 and -L30 (clamp): 0.14 to 1.5 mm² (AWG26 to 16)

Note

- On the 10-CH, Medium-Speed Universal Input module, RTD input terminals A and B are isolated on each channel. Terminal b is shorted internally across all channels.
- Measurement using RTD cannot be performed with the 30-CH, Medium Speed DCV/TC/DI Input Module.
- When the plate with screw terminal (model 772080) is connected to the 10-CH, Medium-Speed Universal Input Module, the terminal arrangement differs from that of clamp terminals, so wire according to the markings on the terminal cover.

5. Wiring Procedure

• Wiring the 4-Wire RTD Resistance Input Modules

• DC voltage input/DI (contact) input

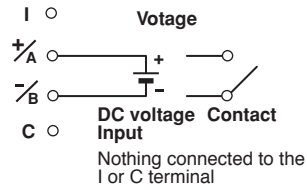

• RTD input, resistance input

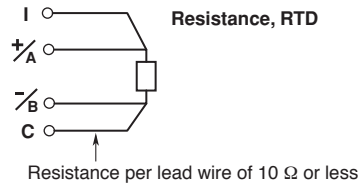

• DC current input

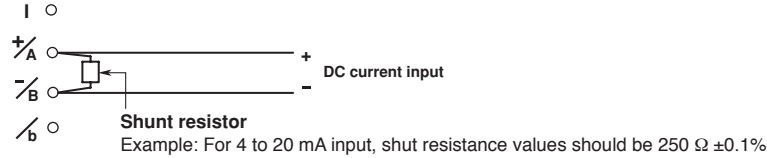

Terminal type: Clamp
Applicable wire size: 0.14 to 1.5 mm² (AWG26 to 16)

• Wiring the Strain Input Modules

• One-Gauge Method

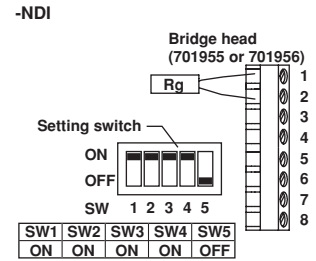
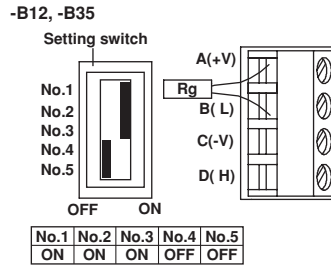
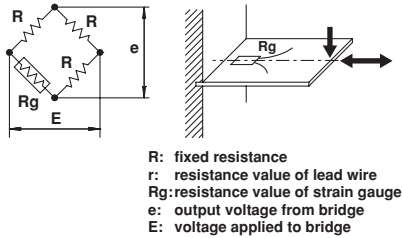

• One-Gauge Three-Wire Method

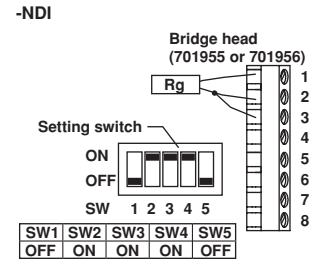
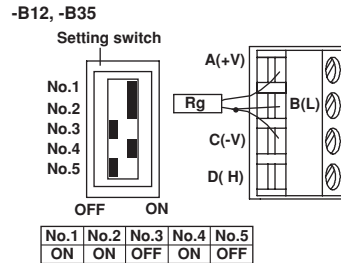
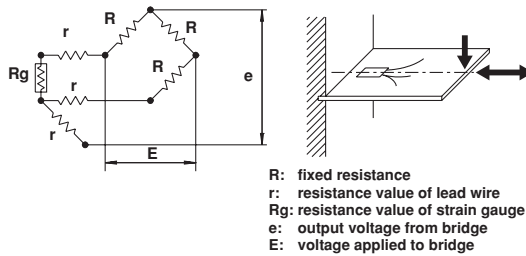

• Adjacent Two-Gauge Method

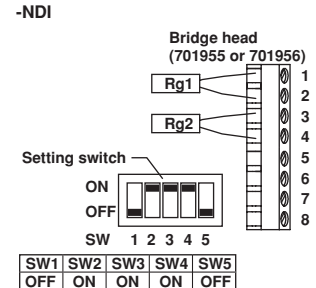
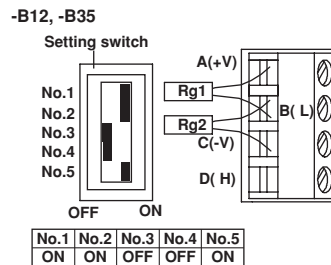
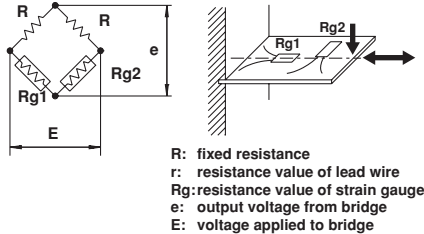

• Opposing Two-Gauge Method

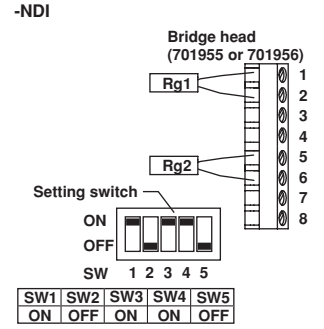
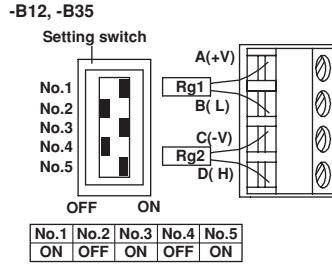
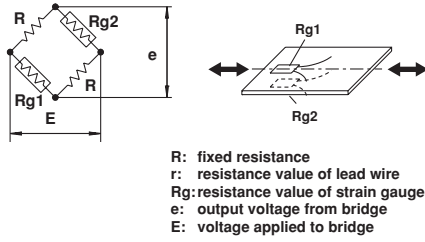

• Opposing Two-Gauge Three-Wire Method

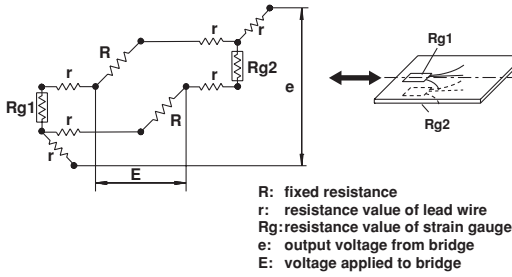

-B12, -B35
 Cannot be connected.
 Use -NDI.

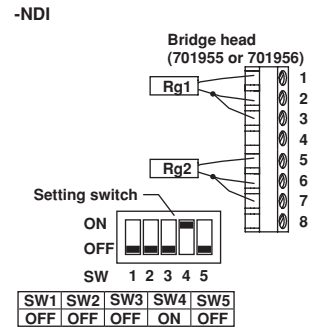

• Four-Gauge Method

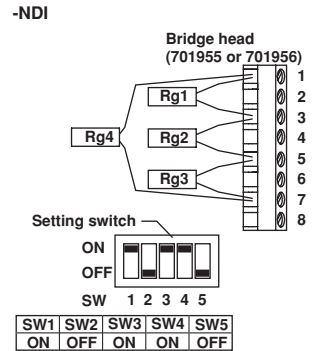
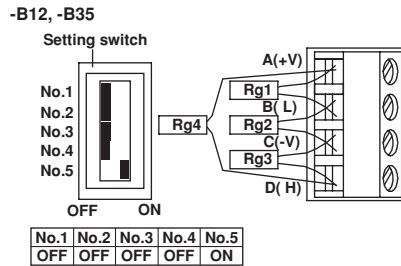
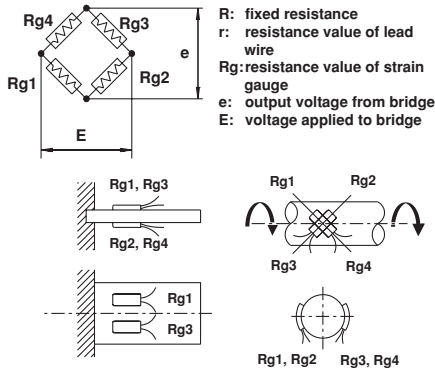

5. Wiring Procedure

• Wiring the Pulse Input Module and Digital Input Modules (-D05, -D24)

Note

- With the pulse input module and digital input module, the (-) terminal and unassigned terminals on all channels are shorted internally.
- When the screw terminal plate (model 772080) is connected to the pulse input module and digital input module, the terminal arrangement differs from that of clamp terminals, therefore wire according to the markings on the terminal cover. Do not connect anything to the b terminals.

Wiring the Pulse Input and Digital Input (-D05) Modules

• Contact input

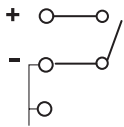

• Transistor input

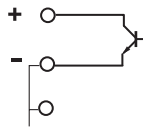

• 5-V logic input

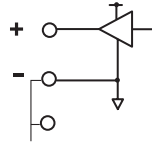

Main Input Specifications (for Pulse Input and Digital Input (-D05))

Input type:	DI (non-voltage contact, open collector, and 5 V logic)
Input format:	Pull-up at approximately 5 V/approximately 5 k Ω , common electric potential between channels
Minimum detection pulse width:	Pulse input: 4 μ s Digital input (-D05): Twice the measurement interval or more
Input threshold level:	<ul style="list-style-type: none"> • Pulse input Non-voltage contact or open collector: Counts when changing from contact open (100 kΩ or more) to contact close (100 Ω or less) 5-V logic: Counts when changing from 1 V or less to 3 V or more • Digital input (-D05) Non-voltage contact or open collector: ON at 100 Ω or less and OFF at 100 kΩ or more 5-V logic: OFF at 1 V or less and ON at 3 V or more
Contact/transistor rating:	Contact with a rating of 15 VDC or greater and 30 mA or greater Vce and Ic are transistors with ratings of 15 VDC or more, and 30 mA or more, respectively.
Terminal type:	Clamp
Applicable wire size:	0.14 to 1.5 mm ² (AWG26 to 16)

Wiring the Digital Input (-D24) Module

• 24-V logic input

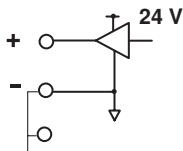

Main Input Specifications (for Digital Input (-D24))

Input type:	DI (24-V logic)
Input format:	Common potential between channels
Minimum detection pulse width:	Twice the sampling interval or more
Input threshold level:	24-V logic: OFF at 6 V or less and ON at 16 V or greater
Terminal type:	Clamp
Applicable wire size:	0.14 to 1.5 mm ² (AWG26 to 16)

• Wiring the Analog Output Modules

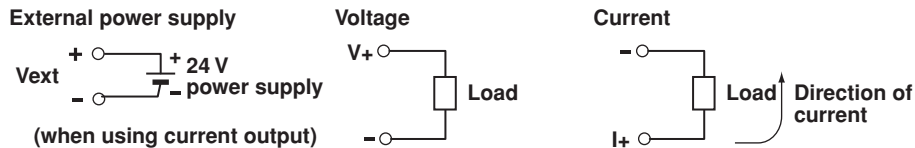

Main Output Specifications

Terminal type:	Clamp, attached and removed in units of 4 channels
Load impedance:	Voltage 5 k Ω or more Current 600 Ω or less
Applicable wire size:	0.08 to 2.5 mm ² (AWG28 to 12)

CAUTION

Two power supply terminals are connected internally. Therefore, do not connect a separate external power supply to them as fire can result. If external power is connected to one power supply terminal, use the other power supply terminal for connection with another analog output module.

• Wiring the PWM Output Modules

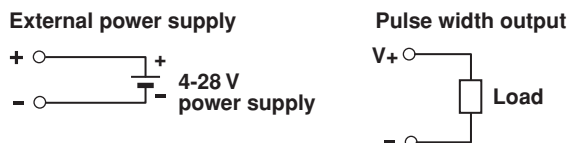

Main Output Specifications

Output capacity:	1A/ch max, however, 4 A or less total for all modules ^{*1, *2}
Terminal type:	Clamp, attached and removed in units of 4 channels
Applicable wire size:	0.08 to 2.5 mm ² (AWG28 to 12)

*1 A 1A current limit circuit is built in to the output circuit. Once the current limit circuit is ON, the circuit continues to operate unless the external power supply is turned OFF.

*2 This module has a built-in fuse. The built-in fuse protects against fires or abnormal emissions of heat due to load short-circuiting or other abnormalities.

CAUTION

Two power supply terminals are connected internally. Therefore, do not connect a separate external power supply to them as fire can result. If external power is connected to one power supply terminal, use the other power supply terminal for connection with another PWM output module.

• Wiring the Digital Output Modules



Main Output Specifications

Contact mode:	A contact (SPST)
Contact capacity:	250 VDC/0.1 A, 250 VAC/2 A, or 30 VDC/2 A (resistance load)
Terminal type:	Clamp, attached and removed in units of 5 channels
Applicable wire size:	0.08 to 2.5 mm ² (AWG28 to 12)

Note

Do not connect anything to the unassigned terminals of the digital output module.

6. Connecting the Power Supply

⚠ When wiring the power supply, observe the precautions given in the MX100/MW100 User's Manual.

Use a power supply that meets the following conditions:

Rated supply voltage:	AC power supply, 100 to 240
	VACrms
Supply voltage range used:	DC power supply, 12 to 24
	VDC
Rated supply voltage frequency:	AC power supply, 90 to 132,
	180 to 264 VAC
Allowable line frequency range:	DC power supply, 10 to 32VDC
	50/60 Hz
Maximum power consumption:	50/60 Hz \pm 2%
	Up to approximately 70 VA maximum when six modules are used

• Connection Procedure Using the Power Cord (When the Suffix Code of the Power Cord Is 1D etc.)

1. Check that the power switch of the main module is OFF.
2. Connect the power cord plug to the power connector of the MX100/MW100 Data Acquisition Unit. (Use the power cord that came with the package.)
3. Connect the plug on the other end of the power cord to the outlet that meets the conditions above. The AC outlet must be of a three-prong type with a protective earth ground terminal.

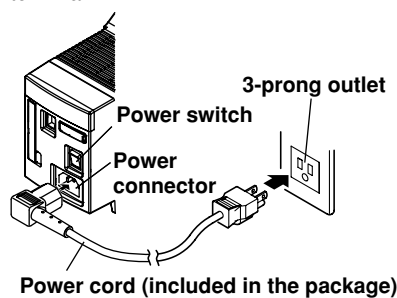

• Wiring Procedure to the Power Supply Terminal (When the Suffix Code of the Power Cord Is 1W)

1. Check that the power supply and the power switch of the main module is OFF.
2. Loosen the screw fixing the power supply terminal cover of the main module in place and open the power supply terminal cover.
3. Connect the power cord and the protective ground cord to the power supply terminals according to the figure below. Use round crimp-on lugs with isolation sleeves (for 4 mm screws) for the power cord and protective ground cord terminals.
4. Close the power supply terminal cover and secure it with the screw.

MX100 main module

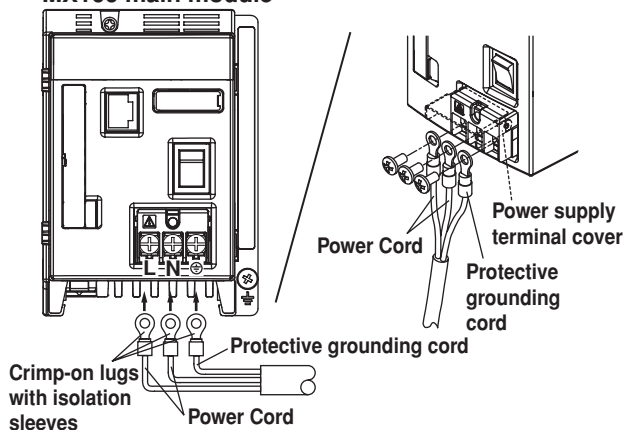

MW100 main module

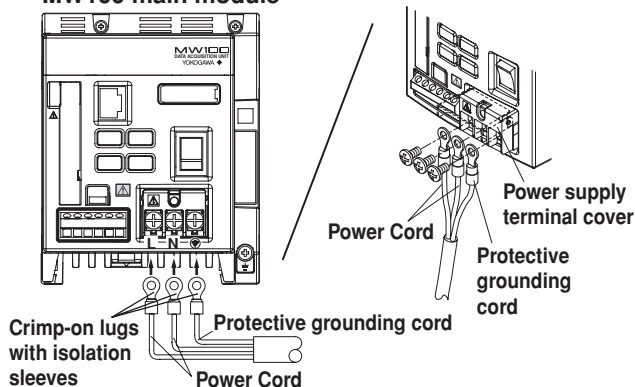

For DC Power (MW100 Only)

1. Check that the power supply and the power switch of the main module is OFF.
2. Loosen the screw fixing the power supply terminal cover of the main module in place and open the power supply terminal cover.
3. Wire the power supply cord and protective ground cord to the power supply terminals according to the figure below. Use round crimp-on lugs (for a 4-mm screw) with insulating sleeves for the terminals.
4. Close the power supply terminal cover and secure it with the screw.

MW100 main module

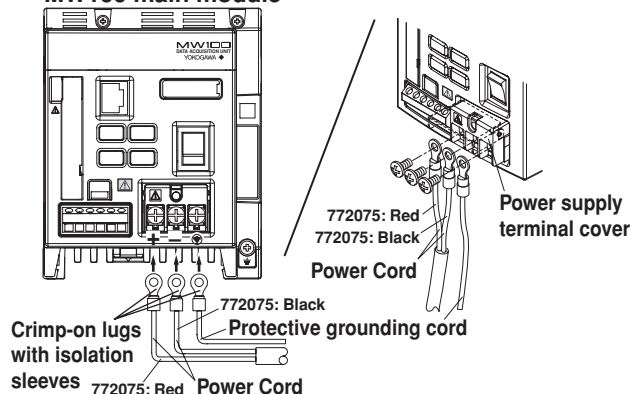

• ON/OFF of the power switch

Pressing the I side of the power switch turns the instrument ON. Pressing the O side turns the instrument OFF. When turned ON, the 7-segment LED illuminates.

7. Connecting to the Ethernet Interface

Connect the Ethernet cable to the Ethernet port of the main module. Use a UTP cable (category 5 or better) or an STP cable for the Ethernet cable.

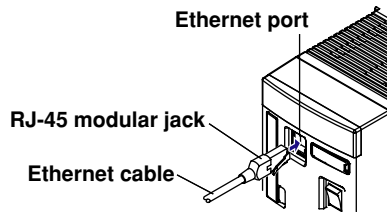

• Checking the Communication Status

You can check the status on the two LEDs at the upper-right and lower-right of the Ethernet port.

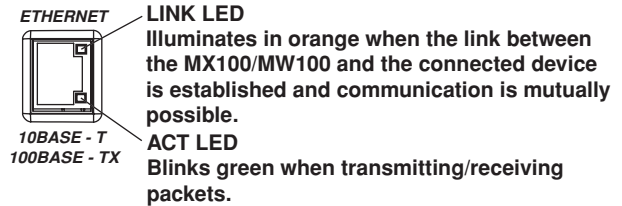

Inserting and Ejecting the CF Card

• Inserting the CF Card

To insert the CF card into the card slot, open the slot cover and face the card's front side to the right.

• Ejecting the CF Card

Be sure to check that the CF card is not being accessed before ejecting the card from the slot. When the CF card is being accessed, the 7-segment LED indicates that processing is taking place.

For the **MX100**, to eject the CF card, open the slot cover while touching the metal for discharging the static electricity, press the access stop switch, and press the eject lever once. Then, press the eject lever that came out once again, and remove the CF card from the slot.

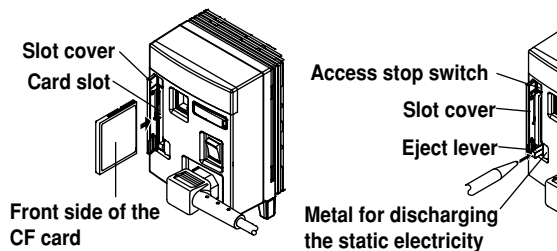

For the **MW100**, be sure to check that the CF card is not being accessed before ejecting the card from the slot. To eject the CF card, first open the slot cover while touching the anti-static metal, then push the eject lever once. Next, push the eject lever (which is pulled out) again, and pull out the CF card.

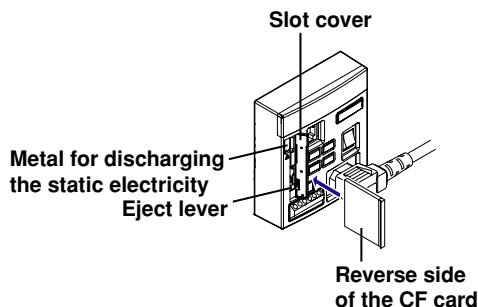

Note

Do not close the slot cover by force while the eject lever is pulled out. Doing so can damage the card slot. When not using the eject lever, push the lever in so that the slot cover can close.

The main module has a two-digit 7-segment LED. The 7-segment LED displays the unit number, operating status, operation complete, and operation error of the MX100/MW100 Data Acquisition Unit

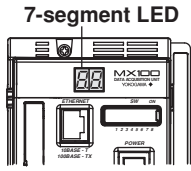

• Unit Number Display

When connected using the MX100 standard software:

Fixed at 00

When connected using MXLOGGER software (MX100 only):

00-19

When connected using the MW100 browser software:

00-89

• Display of the Self-Test Operation at Power on

When the power is turned ON, the LED displays startup indications (such as 00), and a self-test is carried out. While the self-test is in progress, the following displays are repeated.

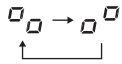

• Display While Processing Is in Progress

The displays shown below repeats when there is access to the CF card, when the CF card is being formatted, or when calibration is taking place.

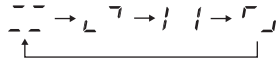

• Unit Confirmation Display

The figure below shows the display that appears when you confirm the MX100 Data Acquisition Unit that is connected using the MX100 Standard Software, MXLOGGER (software sold separately), or MW IP Config Software. The word "--CALL--" flows through the display from right to left.



For details on the display and meaning of operation errors, see section 3.1, "Error Display on the 7-Segment LED and Corrective Actions" in the MX100 Data Acquisition Unit User's Manual or section 4.1, "Error Display on the 7-Segment LED and Corrective Actions" in the MW100 Data Acquisition Unit User's Manual.

• Operation Mode Hold Function Display (Only When the MX100 /DS Option Function Is Enabled)

Following the self-check, the /DS option function execution confirmation "--" is displayed.

• Operation Mode Display (MX100 Only)

The MX100 Data Acquisition Unit has three operation modes: idle mode, measurement mode, and backup mode (measured data saved to a CF card due to the disconnection of communications). The modes are displayed as shown below. In the figure below, 00 indicates the unit number. If the unit number is not 00, the specified unit number is displayed.

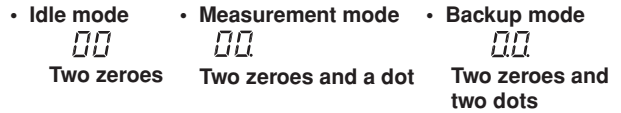

• Display When Operation Is Complete (MX100 Only)

The figure below shows the display that appears when an operation such as IP address configuration, time setup, and measurement condition change is completed. In the figure below, 00 indicates the unit number. If the unit number is not 00, the specified unit number is displayed.



• Key Lock Status (MW100 Only)

A key lock function is included for preventing accidental manipulation of the MW100 front panel keys. The key lock status is indicated by a dot at the bottom of the unit number. The example shown is for a unit of number 00.



• Access Forewarning to the CF Card (MW100 Only)

When saving measured, computed, or thinned data, the dots blink before accessing of the CF card. This indication starts 10 seconds before the access. If you see this indication, quickly finish the insertion or removal of the CF card.

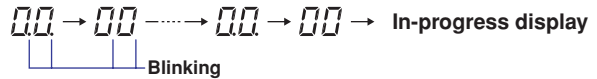

If you are using the multi interval function, this indication may be shorter than 10 seconds. If the time until the CF card is accessed is less than or equal to 5 seconds, the time unit access is displayed numerically.



When performing a manual sample, and when saving report data, the dots do not blink before accessing of the CF card.